

Guidelines for Board
Design For Test (DFT)
Based on Boundary Scan
Part 1

Prepared by
Ben Bennetts, DFT Consultant
for ASSET InterTech, Inc.

April 2006

ABSTRACT:

This document is Part 1 of a 2-part document that contains a series of DFT Guidelines for boards to be tested primarily through the use of boundary scan, based on the IEEE 1149.1-2001 Standard.

Any comments, corrections, suggested additions should be sent to the author, Ben Bennetts, at ben@dft.co.uk.

About The Author/Presenter



Easy, Affordable, Powerful

Dr R G "Ben" Bennetts is an independent consultant in Design-For-Test (DFT), consulting in product life-cycle DFT strategies, and delivering on-site and open educational courses in DFT technologies.

Previously, he has worked for **LogicVision**, **Synopsys**, **GenRad** and **Cirrus Computers**. Between 1986 and 1993, he was a free-lance consultant and lecturer on Design-for-Test (DFT) topics. During this time, he was a member of **JTAG**, the organization that created the IEEE 1149.1 Boundary-Scan Standard.

He is currently an Advisor to the Board of Directors of **ASSET InterTech**, advising the company on future directions of boundary-scan technology. He is also a core-group member of **IJTAG** and **SJTAG** (and currently the SJTAG Chairman), a co-founder and past Program Chair of the IEEE **Board Test Workshop**, founder of the IEEE **European Board Test Workshop**, and the founder and current Chairman of the IEEE's **BTTAC** organisation.

Ben has published over 100 papers plus three books on test and DFT subjects.

© 2006, Bennetts Associates
ASSET InterTech, Inc.
Slide 3
Last revised: March, 2006



DFT Guidelines: Part 1



Easy, Affordable, Powerful

**Boundary-Scan Testability:
Board-Level Guidelines (1)**

General Guidelines

**Ben Bennetts, DFT Consultant
Bennetts Associates, UK**

Tel: +44 1489 581276 E-mail: ben@dft.co.uk
<http://www.dft.co.uk/>



© 2006, Bennetts Associates
ASSET InterTech, Inc.
Slide 4
Last revised: March, 2006

In this document, we will look at general DFT guidelines specific to the design of boards to be tested through the JTAG/boundary-scan registers of IEEE 1149.1-compliant devices.

Board-Level DFT Guidelines

Easy, Affordable, Powerful

At the Board level:



- ❑ As a board designer, where you have a choice, maximise the use of 1149.1 versions of devices rather than non-1149.1 versions
- ❑ Use 1149.1 devices with validated BSDL
- ❑ Be aware of subordination requirements e.g. IBM's LSSD and compliance-enable conditions (more later)

© 2006, Bennetts Associates
ASSET InterTech, Inc.

Slide 5
Last revised: March, 2006



First, maximize the use of 1149.1-compliant devices. The more JTAG (boundary-scan) register access you have, the more fault-coverage will be obtained: both between BS and BS devices and between BS and non-BS devices. Note also that higher fault coverage can be achieved by using unused boundary-scan (JTAG) pins to control buffer direction and output enable signals of simple devices like Texas Instruments' 244 and '245 buffer devices.

Make sure the BSDL files have been validated. See Chip DFT Guidelines for more on BSDL compliance checking.

Note, some devices, notable IBM LSSD devices use the subordination feature of the 1149.1 Standard. In certain LSSD devices, internal LSSD structures are used to test the internal logic of the device, including the 1149.1 logic (TAP controller, etc). This raises a question: who's in charge – 1149.1 or the internal test structures? To answer the question, 1149.1 allows an internal test structure, such as LSSD, to be in charge (i.e. 1149.1 is subordinated to LSSD) but when the full 1149.1 feature set is required, certain pins are held at a fixed level. These pins are called compliance pins and they must be directly accessible in order for the part to become compliant to 1149.1.

Compliance-enable pins are also available on certain CPLDs. We will discuss what to do with these pins later.

Board-Level BS Infrastructure

Easy, Affordable, Powerful

- ❑ Design a simple BS infrastructure (global distribution of TMS, TCK and single daisy-chain TDO-to-TDI interconnects), or use Multiplexers, Jumpers or Scan-Path Linkers (or similar) to control dynamic/secondary paths – more later.
- ❑ If you are tempted to use more-sophisticated scan-chain constructions, such as independent TMS signals, check first that the tester software can handle this infrastructure

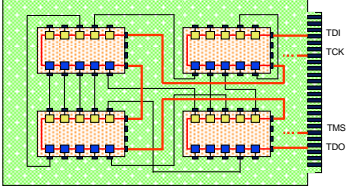

© 2006, Bennetts Associates
ASSET InterTech, Inc.
Slide 6
Last revised: March, 2006



It is possible to design complex scan-chain configurations at the board level e.g. different TMS lines going to subsets of different devices; direct rather than daisy-chained access to individual TDI and TDO pins; etc. The advice here is: make sure the PC-based board tester can handle such infrastructures and “walk before you run”. If you want to read up on these more-complex structures, take a look at Sasidhar’s paper:

Sasidhar et al., “Testing NASA’s 3D-stack MCM space flight computer”, IEEE Computer Society Design & Test of Computers, July-Sept., 98, pp. 44-55

Access to TAP Signals

Easy, Affordable, Powerful

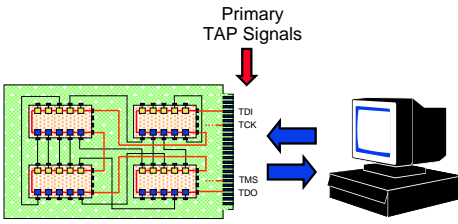

- ❑ Allow direct primary access from the tester to all board top-level TAP signals: TDI, TDO, TMS, TCK and TRST*

© 2006, Bennetts Associates
ASSET InterTech, Inc.
Slide 7
Last revised: March, 2006



Be careful with the design and distribution of the on-board TAP signals. Allow direct access to all TAP signals from the primary contact to the board: edge connector or plug and socket. Treat both TCK and TMS as critical signals i.e. properly balanced, no skew, properly buffered (with no inversion), monotonic (continuously rising/falling), etc. Terminate the signals to avoid reflections. Note that the TCK frequency is determined by the slowest device on the

board. (Maximum TCK frequency for a device is specified in the BSDL file for that device.) Place a weak pull down on the TRST* signal – see later.

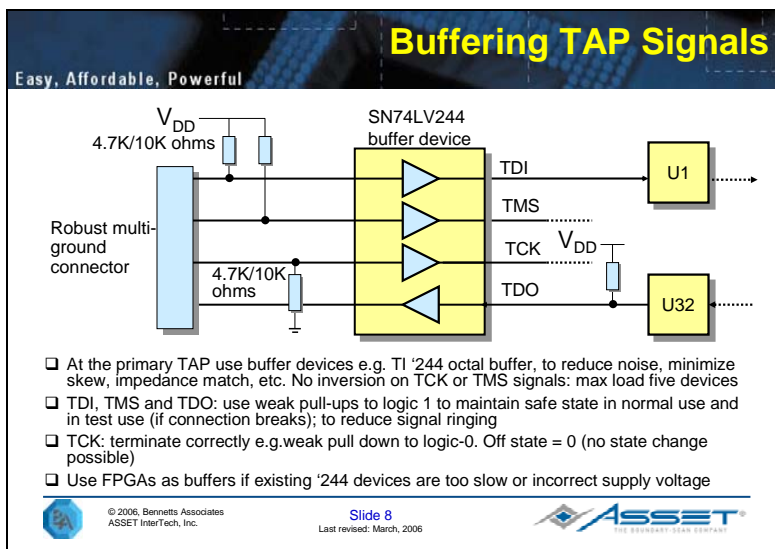

It is recommended to buffer the primary TAP signals on/off the board for the following reasons:

- to prevent noisy backplane signals from reaching the on-board devices;
- to handle impedance mismatches between tester and the board, tester drivers and board fanouts, cable length etc.;
- to allow for a faster speed TCK because impedance mismatch issues can be minimized and possibly matched with the tester through a special buffer board;
- to not limit the cable length between the tester and the board; and
- to allow safe states to be maintained on the signals during normal use and during test use (if the tester-to-board cable becomes disconnected).

Where designs have buffers and you want to change them for scan devices, the usual problem is that scanable buffers on the market tend to be a bit out-of-date and too slow or the wrong voltage/technology. So why not use a programmable logic device? It is relatively easy to design a CPLD or FPGA to act as a buffer of almost any complexity. You may even absorb several buffers into one programmable logic device, saving board space. They are usually more than fast enough, and many not-so-new ones are very cheap now.

Layout of TAP Signals: TCK and TMS

Easy, Affordable, Powerful

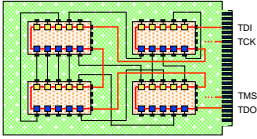

- ❑ Design TCK and TMS board distribution with care: no skew when all BS registers are connected for **EXTEST** use
- ❑ Specify TCK as **CRITICAL** signal during layout
 - Properly balanced (no skew)
 - Properly terminated
- ❑ Design TMS to have no skew relative to TCK
- ❑ Note: max on-board TCK is determined by the slowest device on the board

© 2006, Bennetts Associates
 ASSET InterTech, Inc.

Slide 9
Last revised: March, 2006



Be careful with the design and distribution of the on-board TAP signals. Treat both TCK and TMS as critical signals i.e. properly balanced, no skew, properly buffered (with no inversion), etc. But note that what really counts between TCK and TMS is that TMS is stable when a value change on TCK occurs.

Terminate the signals to avoid reflections. Note that the TCK frequency is determined by the slowest device on the board. (Maximum TCK frequency for an 1149.1 device is specified in the BSDL file for that device.)

Layout of TAP Signals: TDI, TDO

Easy, Affordable, Powerful

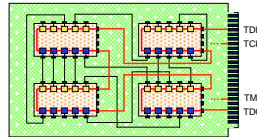

- ❑ Place an appropriate pull-up on the last TDO e.g. 4.7K - 10K ohm. Note: some design guidelines advise a 22 – 33 ohm series resistor on long TDO-to-TDI interconnects in the chain.

© 2006, Bennetts Associates
 ASSET InterTech, Inc.

Slide 10
Last revised: March, 2006



TDI, TDO and TRST* signals also require attention in terms of drive capability, series resistors, terminating resistors and pull-ups/pull-down resistors. The values quoted in the slide are typical values, found in the literature on this subject.

Board TRST*: Floating or Tied?

Easy, Affordable, Powerful

1149.1 requires TRST* internal to go high (logic-1) when left open-circuit
 If the master TRST* signal is left floating during normal operation and there is no internal power-up reset to the TLR state (not mandated when TRST* is supplied), the 1149.1 TAP controller can power up in any state.

© 2006, Bennetts Associates
 ASSET InterTech, Inc.

Slide 11
Last revised: March, 2006

Section 6.3 of the 1149.1 Standard states that, "The TAP controller shall be forced into the Test-Logic-Reset controller state at power-up either by use of the TRST* signal or as a result of circuitry built into the test logic". It is not necessary to provide an internal power-up reset if the TRST* signal has been supplied. If this is the case, what should a designer do with TRST* lines on a board once the board has been tested and is now working normally in a system – leave it floating or tie it low?

The 1149.1 Standard requires TRST* to go high (logic-1) when left open-circuit so that the device is tolerant to an open-circuit fault on the TRST* pin of any 1149.1-compliant device. But, this means that if the master TRST* signal is left floating during normal operation, the 1149.1 devices can potentially power-up in an unsafe state. One solution is to hold TRST* constantly low while the board is operating normally. This and other solutions are discussed in the following slides.

Note: if the TRST* signal is not incorporated into the 1149.1-compliant devices, the device must contain an internal power-up reset and the problem does not exist.

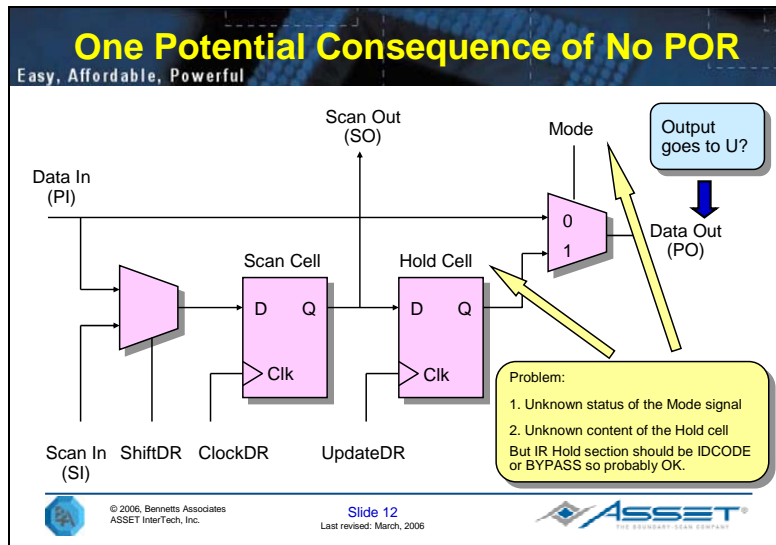

Here, the potential problem is illustrated with the BC₁ boundary-scan cell. The output multiplexer Mode control signal is generated by the decoded output of the Instruction register. If the register is not initialised (to the Test-Logic Reset state), then the value of the Mode control signal could be unknown. If the Mode control line powers up as 1, then the unknown state of the Hold Cell will be passed to the output pin.

Footnote. Strictly speaking, the Hold section of the Instruction Register should power up with the opcode for either the IDCODE instruction (if the Identification register is present), else for the BYPASS instruction. Both these instructions maintain the chip in its functional mode, not test mode. In functional mode, the Mode signal on a BC₁ boundary-scan cell should be logic 0, not logic 1. So, although the state of the boundary-scan (JTAG) cell may be unknown, this unknown value should not be presented to the output pin.

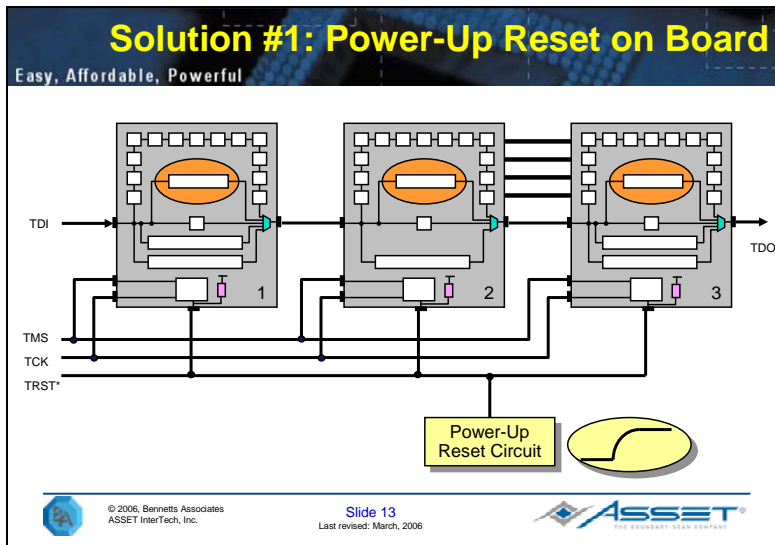

One solution is an automatic power-up reset circuit on the board. This solution is simple but usually not used. The next slide shows the most common solution.

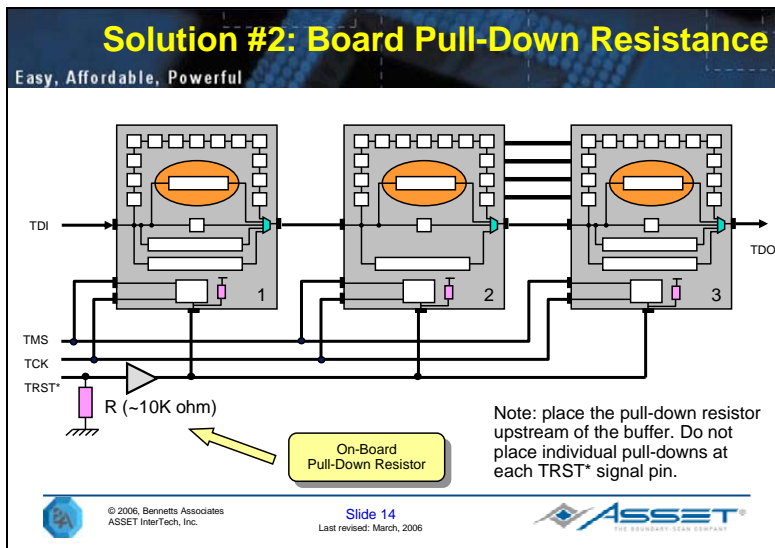

Another solution is to place a weak pull down (typically around 10K ohm) on the TRST* line that

- overcomes the parallel sum of the device internal pull ups, and
- is easily driven high by a PC-based Board tester.

This solution is common and used by Motorola (see ITC2000, Paper 2.3) but the value of the pull-down resistor is critical if there is no buffer on the TRST* signal input. Too low, and a PC-based driver may not be able to drive

TRST* high enough to be sensed reliably as a logic 1 by all boundary-scan TRST* inputs. Too high, and the board will contain a voltage divider that may drain considerable power from, say, a battery power-supply system.

Note, when the board contains a very large number of JTAG/boundary-scan devices with the TRST* signal provided, the parallel sum of the internal TRST* pull-ups will become very low. Under these conditions, it is recommended to use a buffer to drive the primary TRST* signal onto the multiple TRST* signals and then to place the pull-down resistor on the primary side of the buffer, as shown in the Figure above. This solution removes the objections above.

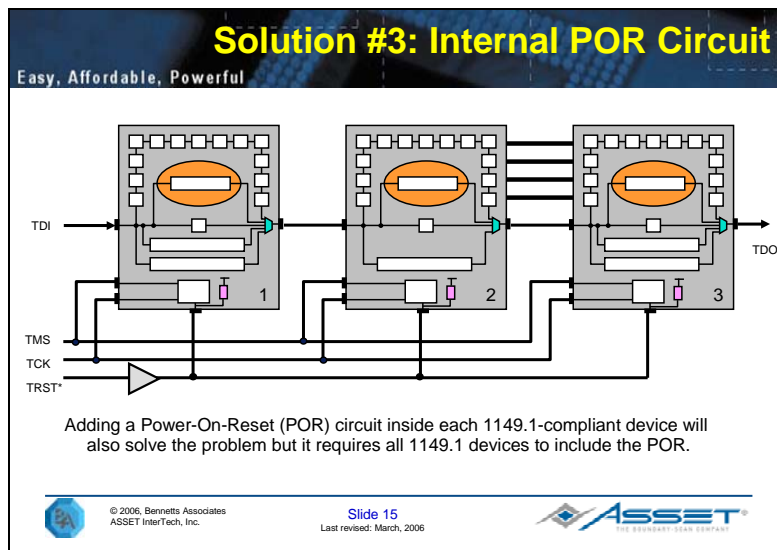

If each 1149.1-compliant device contains a Power-On-Reset (to the Test-Logic/Reset state), then the problem goes away. But, every device in the chain, including those devices without a TRST* signal, has to have this facility for it to work correctly at board level.

Testing The Tester: Resolving Opens

Easy, Affordable, Powerful

"Testing the tester" via IR-Scan or DR-Scan can lead to ambiguous diagnosis if there is an open on a TDO-to-TDI interconnect.
 "Solution: add test points or flying probe/in-circuit nails onto these interconnects

© 2006, Bennetts Associates
 ASSET InterTech, Inc. Slide 16 ASSET
 Last revised: March, 2006 THE BOUNDARY-SCAN COMPANY

Testing the tester can be done either by an IR-Scan or a DR-Scan. IR-Scan places the Instruction register between TDI and TDO and then captures and shifts out the internal hard-wired 01 in the two least significant bits of the register. DR-Scan places the Identification register, if present, else Bypass register between TDI and TDO and then captures and shifts out the internal hard-wired values (1 + 31 bits for Identification, 0 for Bypass). If there is an open circuit between a TDO-out and the next TDI-in, it is not possible to identify at what end the open has occurred. Consequently, the diagnosis is to both devices. Placing a test point or flying probe/in-circuit nail on these interconnects is a simple solution that allows the open to be located to just one of the devices.

Tying-Off Control Pins

Easy, Affordable, Powerful

Use weak pull-ups/downs for tied-off pins, not direct connection to Power or Ground. This allows the pin to be pulled against the resistor in test mode

© 2006, Bennetts Associates
 ASSET InterTech, Inc. Slide 17 ASSET
 Last revised: March, 2006 THE BOUNDARY-SCAN COMPANY

If bidirectional (IO) or three-state (OZ) control pins are tied-off at board level, tie off with a weak pull-up or pull-down resistor rather than connect direct to the Power or Ground rails. This allows an ICT/FPT nail to be used during test

mode to change the status of the pins, plus it allows detection of a missing or open-circuit resistor through a simple parametric test.

Board-Level Ground Bounce

Easy, Affordable, Powerful

20 x Driver (TX) boundary-scan cells

20
0-to-1
or
1-to-0
changes

20 x Sensor (RX) boundary-scan cells

TDI

TDO

- Assess the possibility of ground bounce at the board level during application of **EXTTEST** patterns.
 - Update_DR drives simultaneous value changes onto input and output drivers
 - Too many simultaneous changes may cause transients on power or ground
 - Check max Simultaneous Switching Output Limit (SSOL)
 - Note: individual 1149.1 devices should be tolerant of internal ground bounce but this does not guarantee that the board is also tolerant of ground bounce

© 2006, Bennetts Associates
ASSET InterTech, Inc.

Slide 18
Last revised: March, 2006

Although each 1149.1-compliant device should not exhibit internal ground bounce under worst-case switching conditions, there is no guarantee that ground bounce will not happen at board level when all devices are switching worst-case. Some PC-based testers are able to accept a specification for a maximum Simultaneous Switching Output Limit (SSOL) and to constrain the interconnect pattern-generator to conform to this limit but note that this is really not a JTAG/boundary-scan issue. It is more a general board-design issue and the responsibility is with the board designer to ensure no ground-bounce problems for the board no matter what operational mode the board is in – functional or test.

Note: Most big FPGAs state in their data sheet that they cannot support switching of more than a specified number of cells at once. They have so many cells (some pushing 3,000) that the infrastructure to support switching all at once is not practical.

Achieving SSOL Constraints

Easy, Affordable, Powerful

	3		2	
0	0	0		1
0	0	1		0
0	0	1		1
1	0	0		0
	1		2	
Patterns	P3	P2a	P2	P1

Three patterns, P1, P2 and P3, based on the standard counting algorithm produce a SSO of 2 (50%) between P1 and P2, and an SSO of 3 (75%) between P2 and P3. Assume SSO > 50%

© 2006, Bennetts Associates
 ASSET InterTech, Inc.

Slide 19
 Last revised: March, 2006

THE BOUNDARY-SCAN COMPANY

In the 4-interconnect example above, the patterns have been assigned based on the Counting Algorithm – straight up count.

Assume SSOL = 2 i.e. no more than 50% of the boundary-scan or JTAG cells can switch simultaneously

The Counting Algorithm breaks the 50% constraint limit between Pattern 2 and Pattern 3 if Pattern 3 follows the vertical counting pattern of 0001.

Extra test, P2a = 0000, is added to reduce SSOs between pattern 2 and Pattern 3 to 2 and 1 respectively.

Achieving SSOL Constraints

Easy, Affordable, Powerful

	↔	↔	
	2	2	
→	0	0	1
	1	1	0
	0	1	1
	1	0	0

Chip 1

Chip 2

Net 1
Net 2
Net 3
Net 4

Adding extra tests is a work-around solution. A better solution is to use an optimum coding technique that retains the horizontal code properties “at least one 1 and one 0, and unique assignment” plus an additional vertical coding property of “not more than SSOL_{max} changes per adjacent code”. See ITC 2003, P13.4

© 2006, Bennetts Associates
ASSET InterTech, Inc. Slide 20
Last revised: March, 2006

But, changing the horizontal code on Net 2 from 010 to 110 has the same effect and does not incur the extra test. All other basic properties for detection are retained (each code has at least one 1 and one 0, and each code is unique).

The problem of “what is the minimum number of tests to satisfy a maximum SSOL constraint?” has now been solved – see ITC 2003 Paper 13.4 (Hollman et al.)

BS-to-non-BS Interfaces

Easy, Affordable, Powerful

- Design for minimum BS-to-non-BS interference
 - Check availability of IO characteristic data and control/constraint values for non-BS devices
 - Identify transparent (series) components to improve interconnect coverage e.g. non-inverting and inverting buffers, series R, in-line MUX (conditional transparency)
 - Avoid unsafe board states e.g. bus conflicts

© 2006, Bennetts Associates
ASSET InterTech, Inc. Slide 21
Last revised: March, 2006

The figure illustrates some of the issues of interfacing between boundary-scan and non-boundary-scan devices and the resulting data needed for the non-boundary-scan devices on the board. Let us explore the basic requirements.

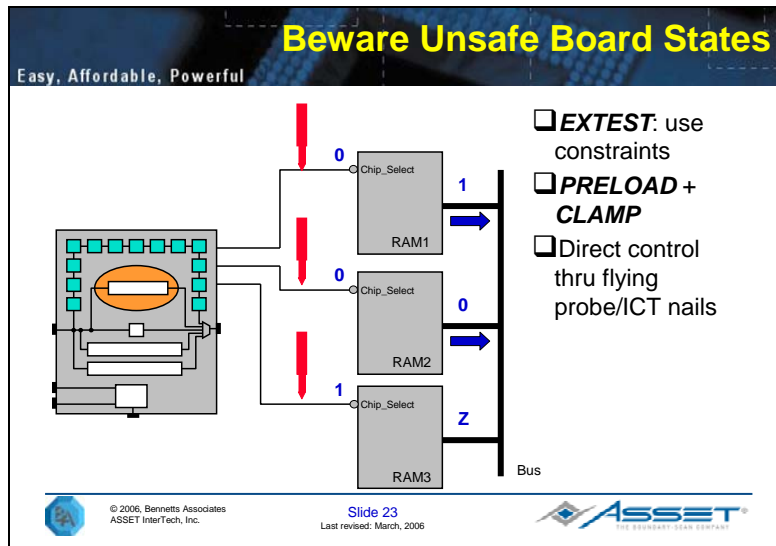

During interconnect test, boundary-scan or JTAG devices are in test mode (EXTEST instruction). If a boundary-scan or JTAG device in test mode happens also to be connected to a non-boundary-scan device, the values driven into the non-boundary-scan device are coming from the JTAG/boundary-scan cells and are the values created by the interconnect pattern-generator. These values have the potential to damage the non-boundary-scan device and the board should be designed to prevent this from happening.

The example above shows three non-boundary-scan RAMs whose *Chip-Select* control inputs are connected to three outputs of a JTAG or boundary-scan device. If the three boundary-scan/JTAG cells are unconstrained, there is a high probability that any two or all three RAMs will be selected simultaneously, thus creating a bus conflict.

One solution is to include the hold section in the boundary-scan cell (as in the BC_1) and to use the EXTEST instruction to load continuously safe values (known as *constraint* values) into the hold sections of these three cells. Alternatively, a set of safe values could be set up by the PRELOAD instruction and applied through the CLAMP instruction, leaving the JTAG or boundary-scan device with its BYPASS register selected. Yet another solution would be to provide an external control on the *Chip-Select* lines and drive the outputs to their high-Z state.

As an aside, it is worth noting that many BSDL files define X to be the safe state on Tristate and Bidirectional pins. In reality, there is no such thing as an X state and the value will default to either 1 or 0. This value is usually program-generation software specific. To avoid surprises, the designer should check that either interpretation of X will not cause damage to driven devices.

Loop-Back Connector Test

Easy, Affordable, Powerful

Connector e.g Ethernet, RS 232, etc

- Scan cells to/from a board connector cannot be tested for open-circuits.
- Solution: use a connector loop-back fixture or a simple 1149.1 device.

© 2006, Bennetts Associates
 ASSET InterTech, Inc.

Slide 24
 Last revised: March, 2006

Are there any boundary scan devices connected directly to an edge connector? If so, can a loop-back test be used to check for opens between the scan cells and the connector pins? Alternatively, can you plug into a dummy 1149.1 device for testing purposes?

Different Voltage Levels

Easy, Affordable, Powerful

- Ideally, group devices with the same voltage levels into the same scan chain ...
- ... or provide voltage converters between different parts of the scan chain

© 2006, Bennetts Associates
 ASSET InterTech, Inc.

Slide 25
 Last revised: March, 2006

Devices on the same board with different voltage levels should be grouped and master TAP signals distributed globally passing through appropriate voltage-level converters. That way, full interconnect tests can still be applied.

Note: final TDO off the board may need to be converted back to the same level as the initial TDI, TMS and TCK levels. It depends on the flexibility of the interface pod.

Handling Non-Compliant Devices

Easy, Affordable, Powerful

Place a zero-ohm jumper between TDI and TDO of suspected non-compliant or boundary-scan non-operational devices in order to bypass them if necessary.

Make sure TMS is disconnected to ensure that the non-compliant device is held in its Test-Logic Reset state (TMS = 1 when open circuit).

© 2006, Bennetts Associates
ASSET InterTech, Inc.
Slide 26
Last revised: March, 2006

Suspected non-compliant devices can cause unpredictable behaviour on the board. If the non-compliance is in the TAP Controller, it may be better to switch out TMS and TCK. In this case, one can make a case for a Power-On Reset (POR) circuit inside the device even though the device contains a TRST* signal. This would be an interesting question to ask 1149.1 synthesis tool providers.

In the example above, the non-compliant device is bypassed (direct link from its TDI pin to its TDO pin) and TMS is open-circuited to ensure that the device is held in its Test-Logic Reset state (based on the TMS = 1, 5 x TCK synchronising sequence) and thus non-responsive to any further change on its TDO and TCK pins.

Alternatively ...

Easy, Affordable, Powerful

Place a potentially troublesome device at the end of the chain and provide an alternative TDO exit off the board

© 2006, Bennetts Associates
ASSET InterTech, Inc.
Slide 27
Last revised: March, 2006

Another solution is to place the potentially-troublesome device at the end of the chain allowing it to be bypassed using an extra TDO-exit. See TDO* above.

Using Un-Used Boundary-Scan Cells

Easy, Affordable, Powerful

E.g. Un-used FPGA pins

Clock distribution

- En A
- En B
- Osc A
- In A
- Osc B
- In B
- Out A1
- Out A2
- Out A3
- Out A4
- Out B1
- Out B2
- Out B3
- Out B4

- Using two unused boundary-scan cells to control system clock distribution to reduce noise, for example.
- Very useful during prototype board debug

© 2006, Bennetts Associates
ASSET InterTech, Inc. Slide 28
Last revised: March, 2006 ASSET
THE BOUNDARY-SCAN EXPERT

Are there any unused JTAG or boundary-scan outputs e.g. from FPGA devices, that can be used to increase the controllability or observability of non-boundary-scan devices?

On-Board Clock-Generator Control

Easy, Affordable, Powerful

- Control watchdog timers or free-running clock generators from BS cells. Needed for Launch-On-Shift internal scan protocols (timed capture + Scan-Enable signals).
- Disable the on-board oscillator (OE = 0) and replace clock with tester-controlled clock: either boundary-scan through EXTEST (slow) or directly from the tester
- Beware of PLL lock range problem (output clocks work across a range e.g. 45 – 60 MHz).

© 2006, Bennetts Associates
ASSET InterTech, Inc. Slide 29
Last revised: March, 2006 ASSET
THE BOUNDARY-SCAN EXPERT

Free-running clock or watchdog timers should be directly or indirectly controllable via boundary-scan or JTAG cells. It should be possible to disable on-board oscillators to quieten the board down during JTAG (boundary-scan) test modes.

Allow Defeatable Tied-Off Control Pins

Easy, Affordable, Powerful

Functional mode:

- Chip 1: outputs active
- Chip 2: bidirects always inputs

Test Mode:

- Chip 1: outputs highZ
- Chip 2: bidirects either outputs or inputs e.g BC_7s

© 2006, Bennetts Associates
ASSET InterTech, Inc.

Slide 30
Last revised: March, 2006

It may happen that devices are constrained to behave in a certain way during functional mode. In the example above, the 3-state pins of Chip 1 are always used as outputs (Chip-Select signal is set to logic-0) and the bidirectional pins of Chip 2 are always used as inputs during normal functional behaviour. In test mode, it might be useful to use the Chip 2 bidirectional pins as output stimulus drivers – maybe to other JTAG (boundary-scan) devices on the bus. If this is the case, Chip 1 3-state output pins should be placed into a safe high-Z mode. If Chip 1 Chip-Select input is tied directly to Ground, the test mode cannot be established. If the Chip-Select signal is tied to Ground through a defeatable pull-down, then a physical nail or unused BS cell can be used to override the weak 0 with a strong 1.

Placing Real Nails: Other Examples

Easy, Affordable, Powerful

Disabling the non-BS device for BS-to-BS interconnect test

© 2006, Bennetts Associates
ASSET InterTech, Inc.

Direct control of a PLD compliance-enable pin

Slide 31
Last revised: March, 2006

More examples on “good” places to position real nails to assist JTAG tests.

Use of Physical Nails: Summary

Easy, Affordable, Powerful

Consider placing Flying Probe/ICT nails on:

- Non-BS device Output-Enable, BiDi-Enable signals
- Boundary-scan signals of emulatable devices (for monitoring)
- Any special control signals needed to effect compliance or otherwise activate boundary-scan modes
- Any signals that de-activate non-BS devices attached to a BS-to-BS interconnect (to simplify interconnect test)
- IO signals of RAMs and non-BS flash devices and the disabling signals of the non-BS devices connected to these IO signals (for quicker control sequences)
- TDO-to-TDI interconnects (to assist scan-chain diagnosis)
- Any other signals required for a non-BS test e.g. defeatable pull-ups/pull-downs, etc.



© 2006, Bennetts Associates
ASSET InterTech, Inc.

Slide 32
Last revised: March, 2006

